



**America's Preferred Supplier of Quality
Spray Booth Systems and Accessories.**



KAYCO Mixing Rooms

Standard Features

- ▶ Galvanized Finish
- ▶ 12" Exhaust Fan
- ▶ Personal door with observation window
- ▶ Light fixture(s) (less bulbs)
- ▶ Various sizes

Kayco Mixing Rooms offer a safe environment to mix and store paint supplies. Available in an array of sizes. Kayco Mixing Rooms are prepunched for easy nut-and-bolt assembly and meet all NFPA 33 requirements.



Optional Features

- ▶ Powder coated white
- ▶ Additional lighting
- ▶ Additional Doors

Kayco Spray Booths Inc. strives to be your preferred supplier of quality spray booth systems and accessories. Our product line offers a diverse array of spray booth configurations that provide you with a high quality solution at an affordable price.

No solution is the same for every business. The KAYCO line of products is designed to allow custom configuration to meet our customers demanding requirements.

Kayco is dedicated to superior customer service before, during and after the sale.

**Call us at 800-529-2640 or visit us on the web at
www.kaycospraybooths.com**

KAYCO PAINT MIXING ROOM DIAGRAM

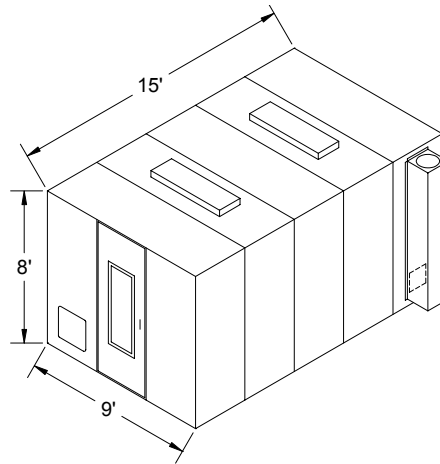

Model	Lights	Inside Dimensions	Outside Dimensions
		W x L x H	W x L x H
MR 69	1	6' x 9' x 8'	6'4" x 10'5" x 9'
MR 612	2	6' x 12' x 8'	6'4" x 13'5" x 9'
MR 615	2	6' x 15' x 8'	6'4" x 16'5" x 9'
MR 618	2	6' x 18' x 8'	6'4" x 19'5" x 9'
MR 621	3	6' x 21' x 8'	6'4" x 22'5" x 9'
MR 624	4	6' x 24' x 8'	6'4" x 25'5" x 9'
MR 99	1	9' x 9' x 8'	6'4" x 10'5" x 9'
MR 912	2	9' x 12' x 8'	6'4" x 13'5" x 9'
MR915	2	9' x 15' x 8'	6'4" x 16'5" x 9'

Features

- ▶ 18 gauge galvanized steel
- ▶ Personal door with observation window.
- ▶ Door interchanges with any panel
- ▶ Pre-punched for nut and bolt assembly
- ▶ Class I division II light fixtures
- ▶ 48" 4 tube fixtures (less bulbs)
- ▶ 12" exhaust fan with 1/3 HP motor.
- ▶ Meets NFPA 33 requirements (electrical, fire suppression, curb not included).
- ▶ Available powder coated white.



- All KAYCO Booths are manufactured in accordance with NFPA 33 and OSHA 1910 codes. Electrical, plumbing and sprinklers (not included) must also conform to these regulations.
- Specifications subject to change

Call us at 800-529-2640 or visit us on the web at www.kaycospraybooths.com